

650nm Coaxial Package Laser Module

K65S03F-0.01W

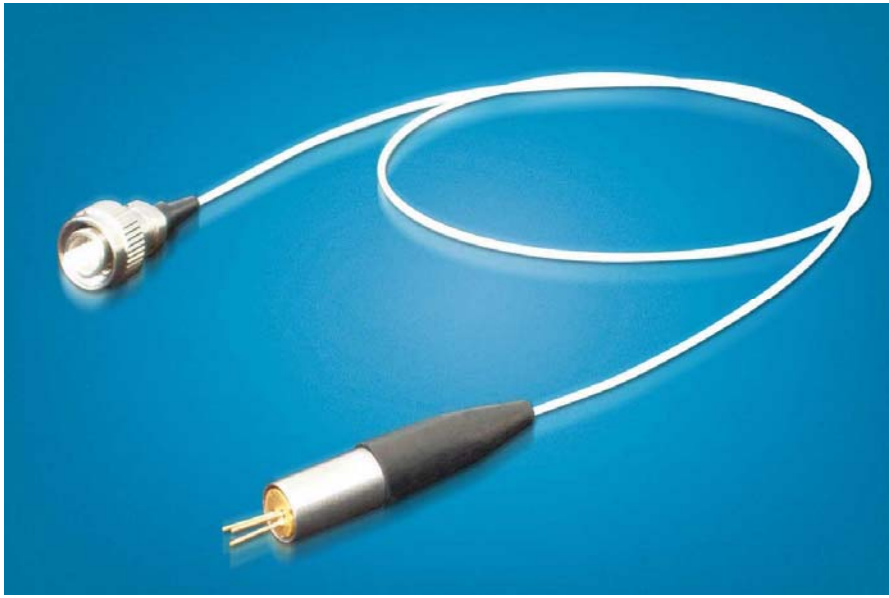

Key Features:

- ◆ 10mW output power
- ◆ 100 μ m or 200 μ m fiber core diameter
- ◆ 0.22NA
- ◆ 650nm wavelength

Applications:

- ◆ Medical use
- ◆ Printing
- ◆ Aiming beam

BWT Beijing's High Power Diode Laser Modules are manufactured by adopting specialized fiber-coupling techniques, resulting in volume products with a high efficiency, stability and superior beam quality. The products are achieved by transforming the asymmetric radiation from the laser diode chip into an output fiber with small core diameter by using special micro optics. Inspecting and burn-in procedures in every aspect come to a result to guarantee each product with the reliability, stability and long lifetime.

Our research staffs are constantly improving and innovating the processing technology in the producing process, based on the professional knowledge and experience accumulated in long-terms. We are also continuously developing new products to meet customers' specific needs.

At BWT Beijing, to provide high quality products with reasonable price is our always goal.

650nm Coaxial Package Laser Module

K65S03F-0.01W

Specifications (25°C)		Symbol	Unit	K65S03F-0.01W
Optical data	CW-output power	P_o	mW	10
	Center wavelength	λ_c	nm	650
	Tolerance of λ	-	nm	± 5
	Spectral width (FWHM)	$\Delta\lambda$	nm	<3
	Temperature drift of λ	-	nm/°C	~0.2
Fiber data ¹	Fiber core diameter	W_c	μm	100
	Numerical aperture	NA	-	0.22
	Fiber connector	-	-	FC, ST,SMA-905
Electrical data	Operation current	I_{op}	mA	50
	Threshold current	I_{th}	mA	30
	Slope efficiency ²	η_D	mW/mA	0.5
	Operation voltage	V_{op}	V	2.4
	Reverse voltage	V_{re}	V	2
PD data	Current	I_{mo}	μA	100~400
Other specifications	Operation temperature	T_{op}	°C	10~30
	Storage temperature	T_{st}	°C	-20~80
	Expected lifetime	MTBF	h	>5,000
	Dimensions (fiber and connector not included)	-	mm	~ $\Phi 6.4 \times 38$
	Lead soldering temperature	T_{is}	°C	260(10 sec.)

1. Other fibers available for OEM applications. Contact BWT Beijing.

2. $\eta_D = P_o / (I_{op} - I_{th})$.

650nm Coaxial Package Laser Module

K65S03F-0.01W

LD Characteristics

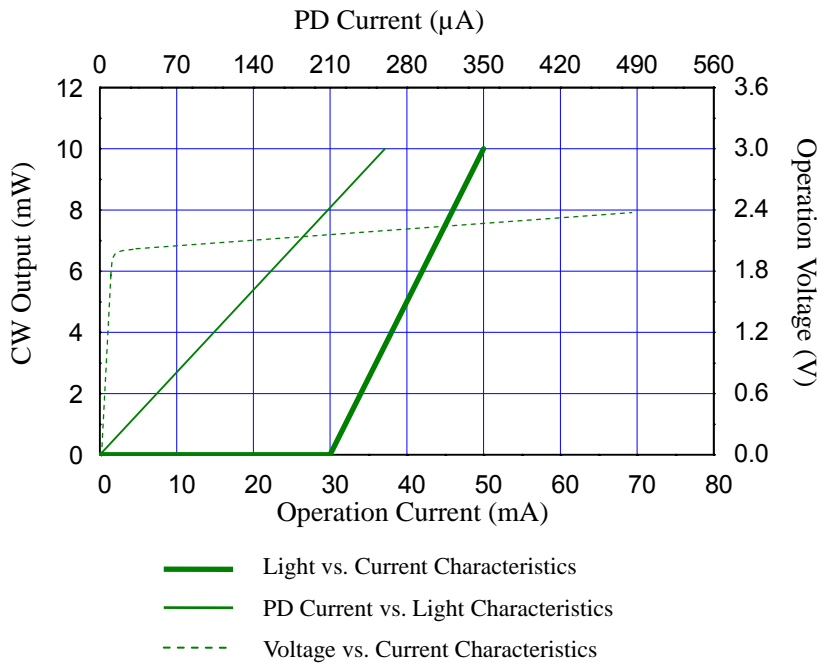

Typ. spectrum (T=25°C)

Typ. spectrum of 650nm diode laser modules

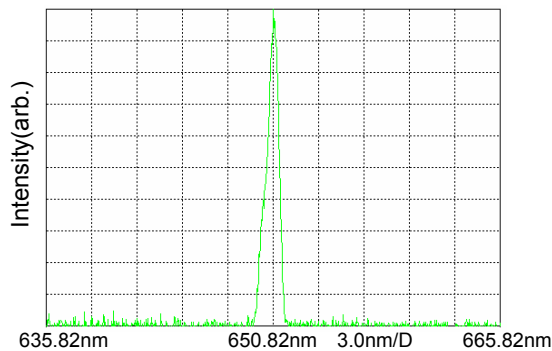

650nm Coaxial Package Laser Module

K65S03F-0.01W

Package Dimensions (mm)

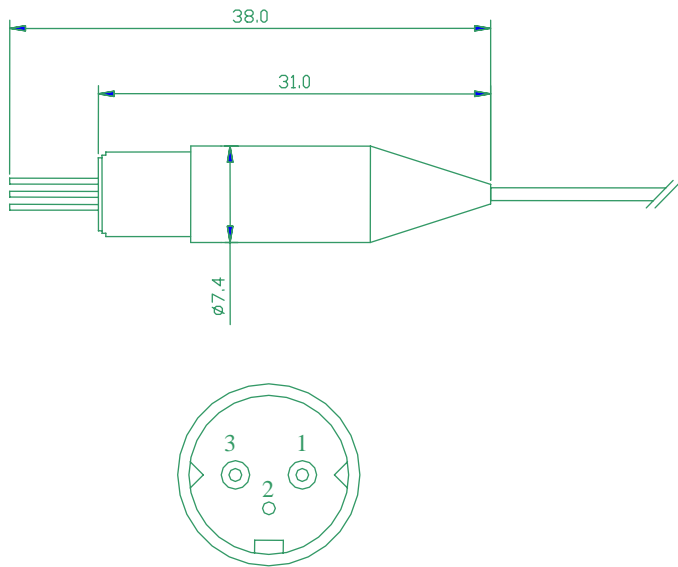

Pin	Function
1	LD Cathode (-)
2	LD Anode (+), PD Cathode (-), Case
3	PD Anode (+)

OPERATING NOTES

- Avoid eye exposure to direct or scattered radiation when the device is in operation.
- ESD precautions must be taken when handling unit.
- Using constant power supplies to guarantee the component works under the limits of its maximum peak optical power.
- The laser diode must be used under the specifications.
- Unit requires a condition to spread the heat as well as possible.
- Keep the fiber end clean before use. Fiber is not allowed to be curved so much. The diameter of curvature should be 300 times greater than fiber diameter.
- Environment temperature is 10°C--30°C.
- Storage temperature is -20°C--80°C, short circuit store.

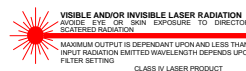

Information and specifications contained herein are deemed to be reliable and accurate. BWT Beijing reserves the right to change, alter or modify the design and specifications of these products at any time with out notice.