

808nm HHL Package Windows Output CW Module

K81S09W-2.50W K81S09W-4.00W K81S09W-5.00W K81S09W-6.00W

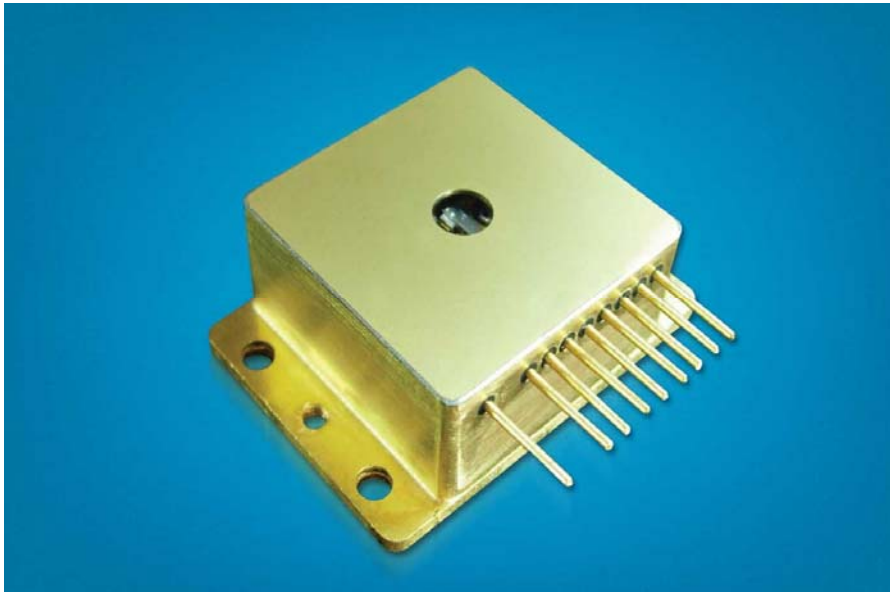

Key Features:

- ◆ 2.5W, 4W, 5W, 6W output power
- ◆ 100 μ m or 200 μ m fiber core diameter
- ◆ 808nm wavelength
- ◆ Window packages

Applications:

- ◆ Solid-state laser pumping
- ◆ Medical/ophthalmic
- ◆ Materials processing
- ◆ Graphic arts
- ◆ Free-space communication
- ◆ Beacons/illumination

BWT Beijing's High Power Diode Laser Modules are manufactured by adopting specialized fiber-coupling techniques, resulting in volume products with a high efficiency, stability and superior beam quality. Inspecting and burn-in procedures in every aspect come to a result to guarantee each product with the reliability, stability and long lifetime.

Our research staffs are constantly improving and innovating the processing technology in the producing process, based on the professional knowledge and experience accumulated in long-terms. We are also continuously developing new products to meet customers' specific needs.

At BWT Beijing, to provide high quality products with reasonable price is our always goal.

808nm HHL Package Windows Output CW Module

K81S09W-2.50W K81S09W-4.00W K81S09W-5.00W K81S09W-6.00W

Specifications (25°C)		Symbol	Unit	K81S09W -2.50W	K81S09W -4.00W	K81S09W -5.00W	K81S09W -6.00W
Optical data	CW-output power	P_o	W	2.5	4	5	6
	Center wavelength ¹	λ_c	nm	808			
	Tolerance of λ	-	nm	$\pm 3, \pm 5, \pm 10$			
	Spectral width (FWHM)	$\Delta\lambda$	nm	<3			
	Temperature drift of λ	-	nm/°C	~0.3			
Emitting data	Emitting dimensions	W×H	μm	100×1	200×1	200×1	200×1
FWHM beam divergence	Parallel to junction	$\theta_{//}$	degree	10			
	Perpendicular to junction	θ_{\perp}	degree	<40, <10, <2			
Electrical data	Operation current	I_{op}	A	2.5	4.2	5.3	6.5
	Threshold current	I_{th}	A	0.4	0.6	0.6	0.6
	Conversion efficiency ²	η	%	40~55			
	Slope efficiency ³	η_D	W/A	0.8~1.2			
	Operation voltage	V_{op}	V	1.8	1.95	2.1	2.2
	Reverse voltage	V_{re}	V	2			
PD data	Current	I_{mo}	mA	0.20~1.50			
TEC data	Max. current	I_t	A	4			
	Max. voltage	V_t	V	9.8			
Thermistor data ⁴	Thermistor	R_0	(K Ω)/β(25°C)	10±5%/3477			
Other specifications	Operation temperature	T_{op}	°C	10~30			
	Storage temperature	T_{st}	°C	-20~80			
	Expected lifetime	MTBF	h	>10,000			
	Dimensions	-	mm	~45×32×18			
	Weight	-	g	~70			
	Lead soldering temperature	T_{is}	°C	260(10 sec.)			

- Other wavelengths available for OEM applications (635nm, 660nm, 670nm, 680nm, 690nm or 980nm). Contact BWT Beijing.
- $\eta = P_o / (I_{op} V_{op})$.
- $\eta_D = P_o / (I_{op} - I_{th})$.
- $R_T = R_0 \cdot \exp(\beta(1/T - 1/T_0))$, ($T_0 = 25^\circ\text{C} = 298\text{K}$).

808nm HHL Package Windows Output CW Module

K81S09W-2.50W K81S09W-4.00W K81S09W-5.00W K81S09W-6.00W

LD Characteristics

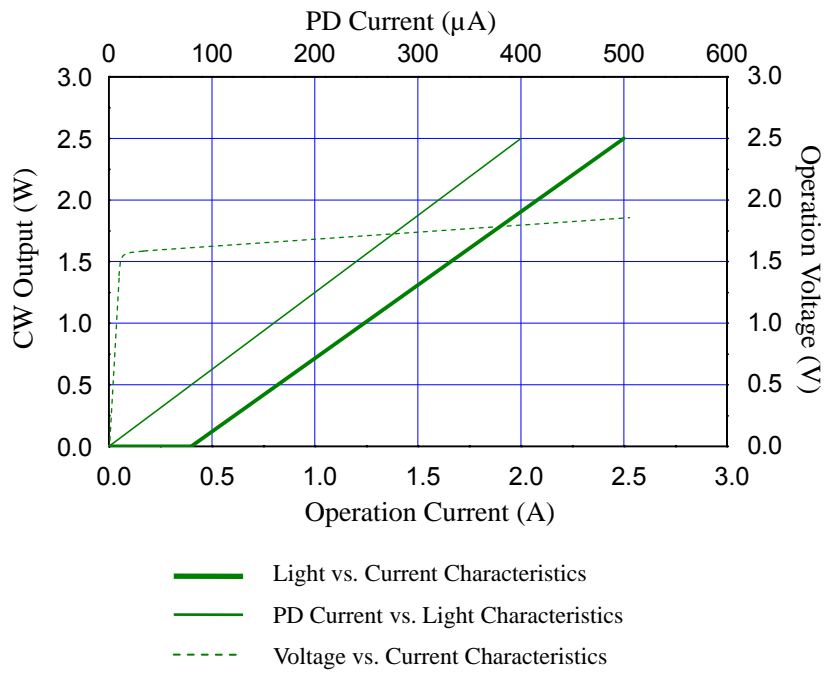

Typ. spectrum (T=25°C)

Typ. spectrum of 808nm diode laser modules

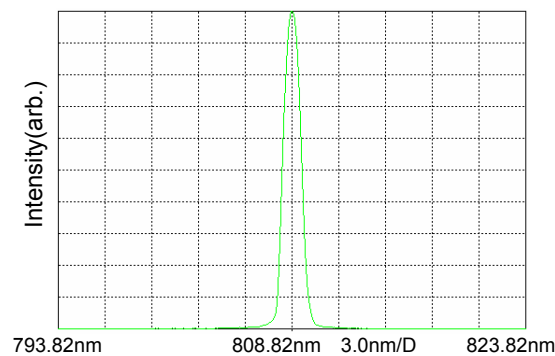

808nm HHL Package Windows Output CW Module

K81S09W-2.50W K81S09W-4.00W K81S09W-5.00W K81S09W-6.00W

Package Dimensions (mm)

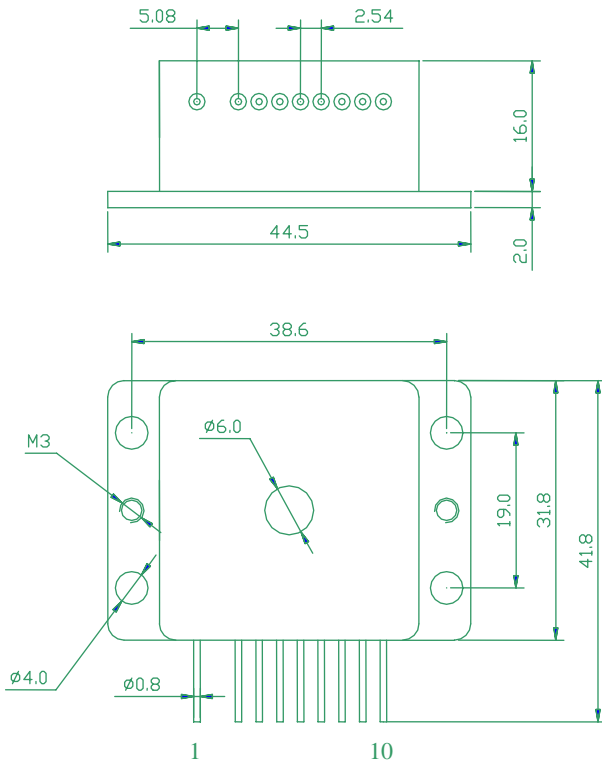

Pin	Function	Pin	Function
1	TEC (-)	6	Thermistor(2)
2	None	7	Laser Cathode (-)
3	Case	8	PD (P)
4	Laser Anode (+)	9	PD (N)
5	Thermistor(1)	10	TEC (+)

OPERATING NOTES

- Avoid eye exposure to direct or scattered radiation when the device is in operation.
- ESD precautions must be taken when handling unit.
- Using constant power supplies to guarantee the component works under the limits of its maximum peak optical power.
- The laser diode must be used under the specifications.
- Unit requires a condition to spread the heat as well as possible.
- Keep the fiber end clean before use. Fiber is not allowed to be curved so much. The diameter of curvature should be 300 times greater than fiber diameter.
- Environment temperature is 10°C--30°C.
- Storage temperature is -20°C--80°C, short circuit store.



VISIBLE AND/OR INVISIBLE LASER RADIATION
AVOID EYE OR SKIN EXPOSURE TO DIRECTOR
SCATTERED RADIATION
MAXIMUM OUTPUT IS DEPENDANT UPON AND LESS THAN
INPUT RADIATION EMITTED WAVELENGTH DEPENDS UPON
FILTER SETTING
CLASS IV LASER PRODUCT



Information and specifications contained herein are deemed to be reliable and accurate. BWT Beijing reserves the right to change, alter or modify the design and specifications of these products at any time with out notice.